

PL - RTV RTVSZ 120 /
SK - TV STOLÍK RTVSZ 120 /
HU - TV ASZTAL RTVSZ 120

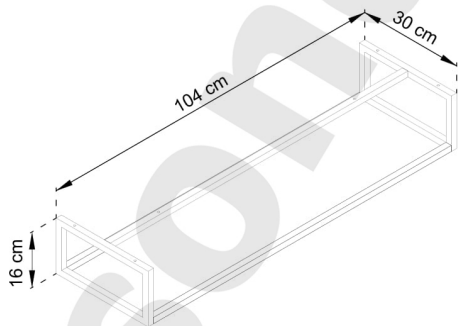

(D) Montageanleitung
(FR) Notice de montage
(NL) Handleiding voor de montage
(CZ) Montážní návod
(HU) Szerelési útmutató
(TR) Montaj talimatı

(GB) Assembly Instructions
(IT) Istruzioni di montaggio
(PL) Instrukcja montażu
(SK) Návod na montáž
(RO) Instrucțiuni de montaj
(RU) Инструкции по монтажу

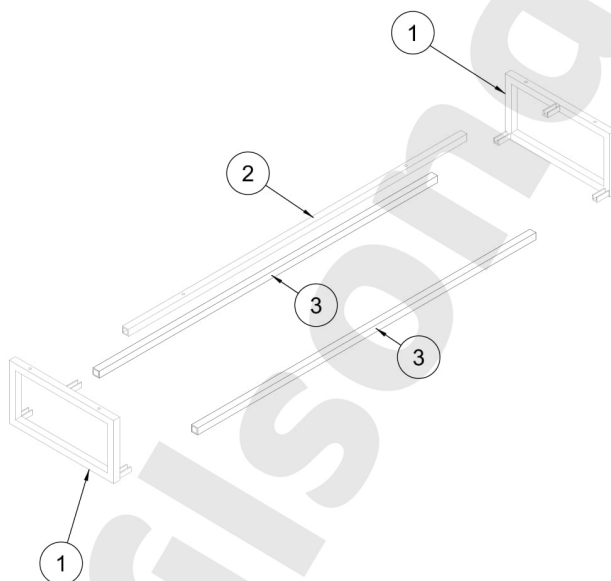

1	300	160	18	x2	1 / 2
2	1004	18	18	x2	1 / 2
3	1004	18	18	x2	1 / 2

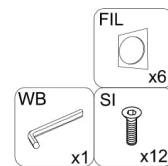

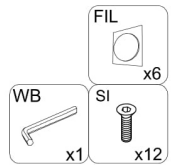
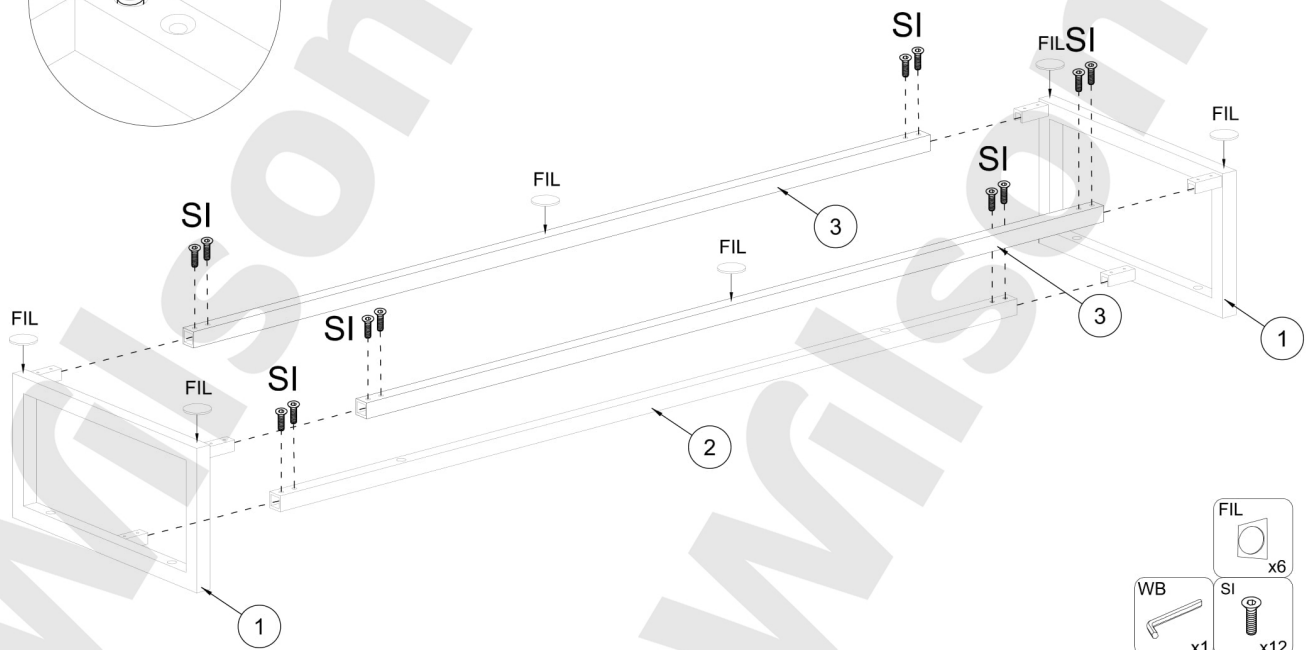
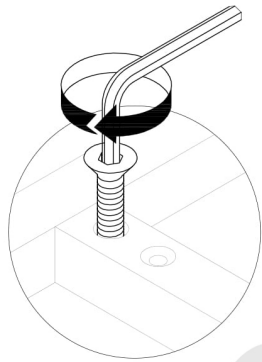

PL - RTV RTVSZ 120 /
SK - TV STOLÍK RTVSZ 120 /
HU - TV ASZTAL RTVSZ 120

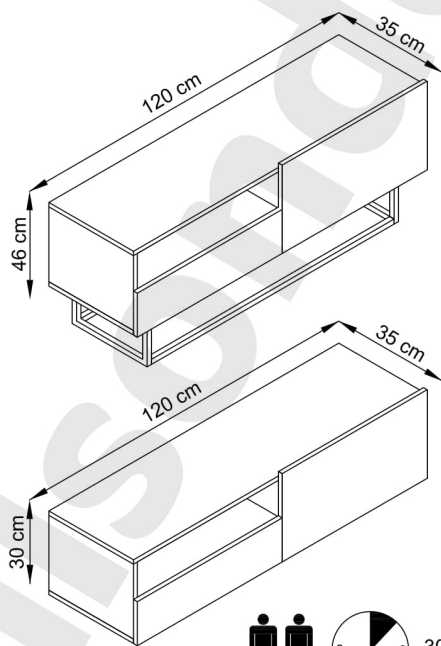
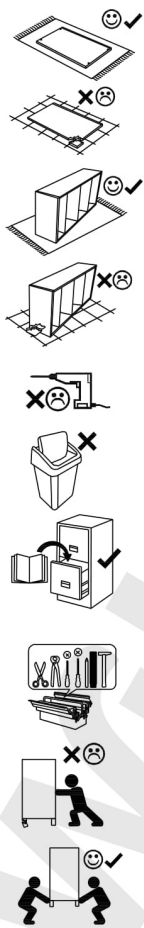

- | | |
|----------------------------------|------------------------------|
| (D) Montageanleitung | (GB) Assembly Instructions |
| (FR) Notice de montage | (IT) Istruzioni di montaggio |
| (NL) Handleiding voor de montage | (PL) Instrukcja montażu |
| (CZ) Montážní návod | (SK) Návod na montáž |
| (HU) Szerelési útmutató | (RO) Instrucțiuni de montaj |
| (TR) Montaj talimatı | (RU) Инструкции по монтажу |

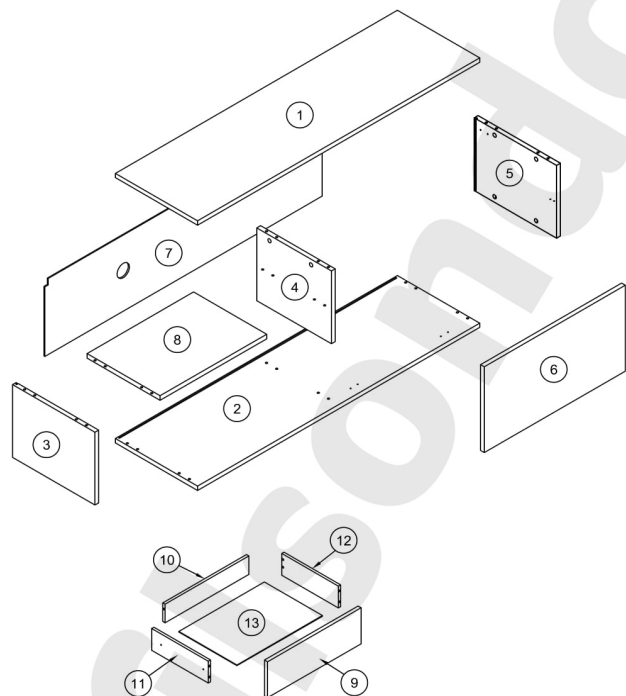

V 3x13 x6	PPW x1	X x10	ND 3,5x16 x19	O x1	W4 x2	K3 4x30 x4	H 6.3x13 x4
P+R x2	C x16	Z x16	B x16	W3 x2	N 3x20 x8	A x20	GLUE x1

⚠ **Uwaga • Upozornění • Achtung • Attention • Caution • Figyelem**
Attenzione • Opgelet • Внимание • Atenție • Upozornenie • Dikkat ⚠

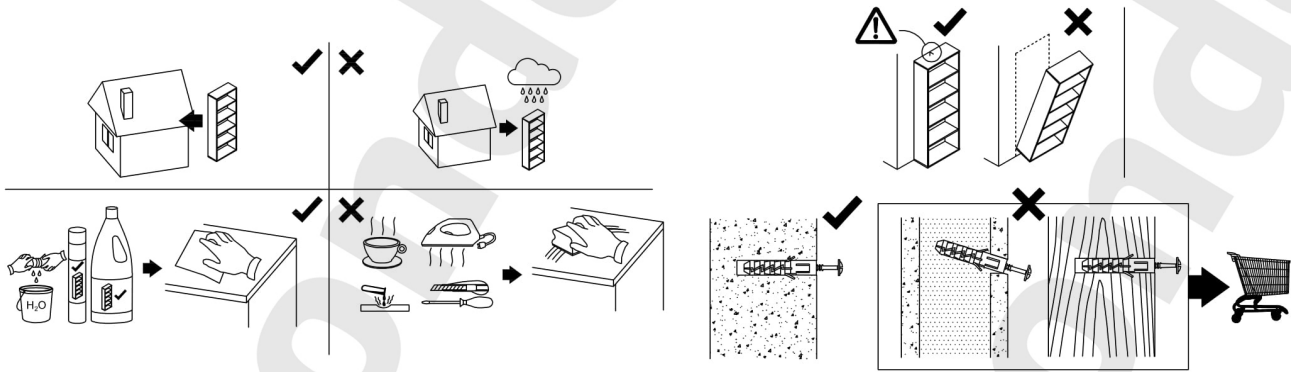

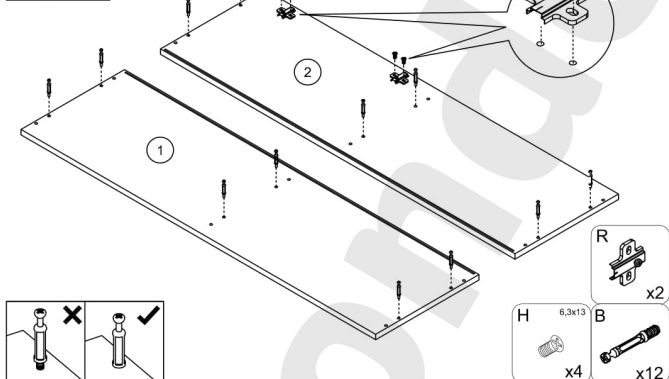
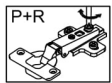

PL	Czyszczenie należy wykonać wyłącznie za pomocą ściereczki lub lekko nawilżonego ręcznika. Nie stosować środków czyszczących do szorowania.
CZ	Čistění je nutné vykonávat výhradně pomocí utěrky nebo lehce navlhčeného ručníku. Nepoužívejte čisticí prostředky obsahující abrazivní částice.
DE	Bitte nur mit einem Staubtuch oder leicht feuchten Lappen reinigen. Keine scheuernden Putzmittel verwenden.
GB	Please only clean with a duster or damp cloth. Do not use any abrasive cleaners.
FR	Le nettoyage se fait uniquement à l'aide d'un torchon ou d'une serviette légèrement mouillée.
NL	Reinig alleen met een stofdoek of een lichtjes vochtige doek. Gebruik geen schurende poetsmiddelen.
IT	Pulire esclusivamente con un panno o un asciugamano umido.
HU	A tisztítás kizárólag törölköző vagy enyhén nedvesített törölköző segítségével végezhető. Súroló hatású tisztítószereket nem szabad használni.
RU	Очищайте от пыли тряпкой или слегка влажной ветошью. Не допускается применение чистящих средств, не предназначенных для ухода за мебелью.
RO	Curățarea trebuie efectuată numai cu o cârpă sau cu un prosop ușor umezit. Nu utilizați agenți de curățare abrazivi.
SK	Čistenie je nutné vykonávať pomocou suchej alebo mierne navlhčenej handričky. Nepoužívajte abrazívne čistiace prostriedky!
TR	Lütfen sadece bir toz bezelye veya hafif nemli yumuşak bir bezle siliniz. Aşındırıcı temizlik mabzermeleri kullanmayın.

PL	Mocowanie do ściany jest jednocześnie zabezpieczeniem przed przewróceniem - konieczne zamontować! Do niektórych rodzajów ścian koniecznie zastosować specjalne kołki mocujące.
CZ	Montáž na stěnu slouží jako ochrana proti převrhnutí - bezpodmínečně umístěte! U některých typů stěn může být zapotřebí speciální hmoždinka!
DE	Wandbefestigung dient als Kippschutz - unbedingt anbringen! bei einigen Wandtypen kann ein Spezialdübel erforderlich sein!
GB	The wall fastening serves to prevent tipping - be absolutely sure to mount it! For certain wall types, a special wall plug may be necessary!
FR	La fixation murale sert de protection contre le basculement - à installer impérativement! Pour certains types de murs il faut des chevilles spéciales!
NL	Bevestiging aan de muur dient als kantelbescherming - zeker en vast bevestigen! Bij enkele muurtypes is een speciale plug misschien vereist!
IT	Il fissaggio alla parete serve da protezione anti-ribaltamento-attaccarla assolutamente! Per alcune strutture di parete può essere necessario un tassello speciale!
HU	A termék a falhoz kel rögzítési, különben az felborulhat! Egyes fal típusoknál speciális típusú kell használni!
RU	Обязательно установите крепление на стене во избежание опрокидывания! Для некоторых типов стен может потребоваться специальный дюбель!
RO	Sistemul de fixare la perete serve ca protecție la răsturnare - de montat obligatoriu! Pentru unele tipuri de pereți este posibil să fie necesar un diblu special!
SK	Upevnenie na stenu slúži ako ochrana pred prevrátením - bezpodmienečne ho vykonať! Pre niektoré druhy stien môže byť potrebná špeciálna hmoždinka!
TR	Duvardaki sabitleme, devrilmeye karşı bir emniyet tedbiridir ve mutlaka monte edilmelidir! Bazı duvar tiplerinde bunun için özel bir dübel gereki olabilir!



1

- R  x2
- H  6,3x13 x4
- B  x12

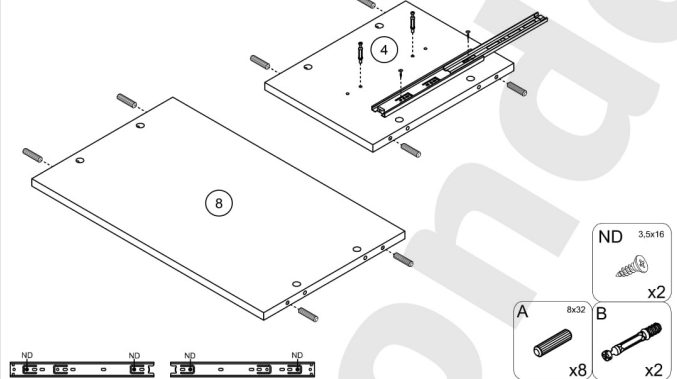



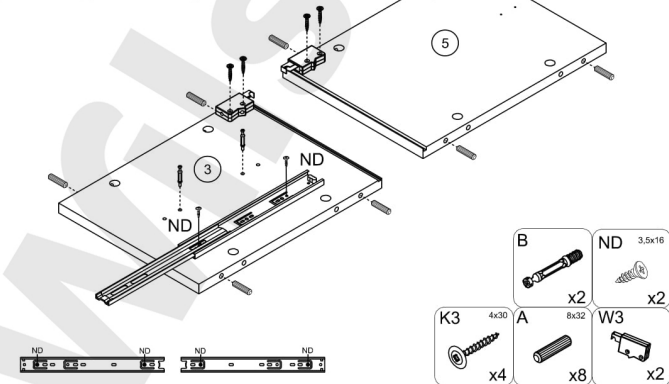
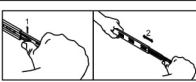

3

- ND  3,5x16 x2
- A  8x32 x8
- B  x2



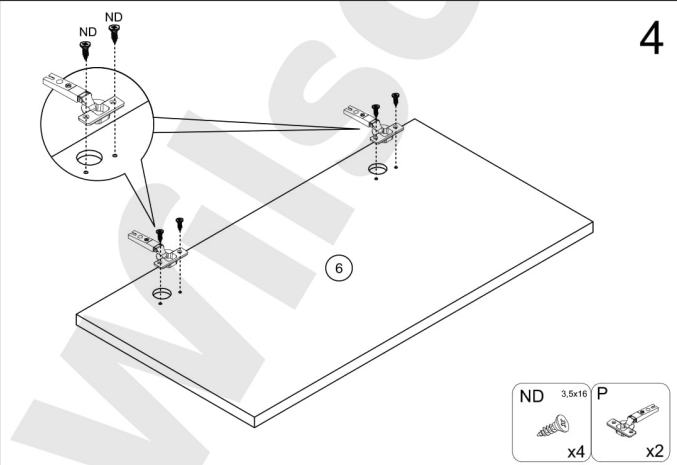

2

- B  x2
- ND  3,5x16 x2
- K3  4x30 x4
- A  8x32 x8
- W3  x2



4

- ND  3,5x16 x4
- P  x2

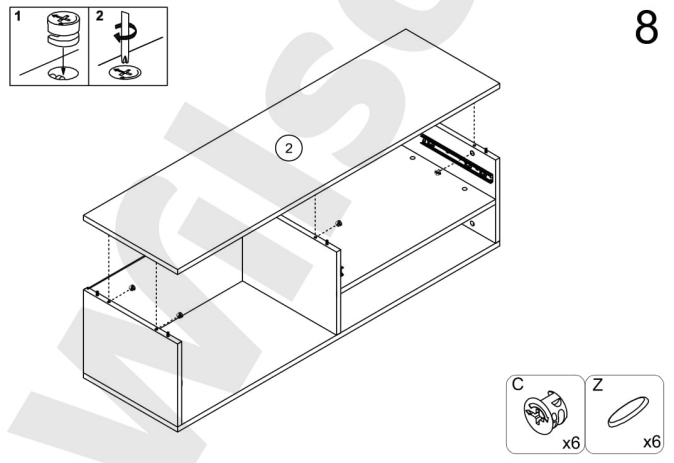
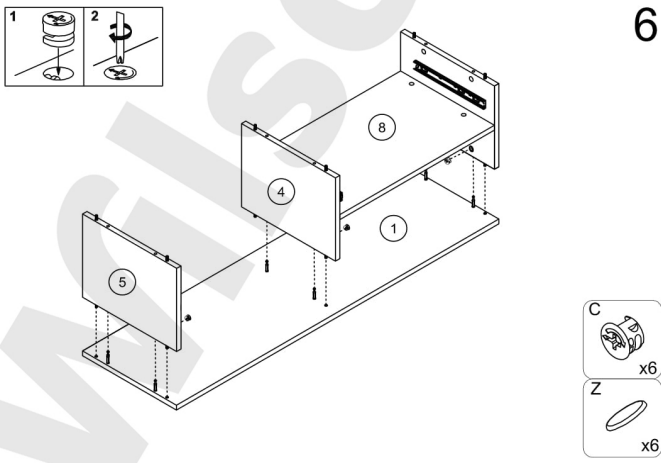
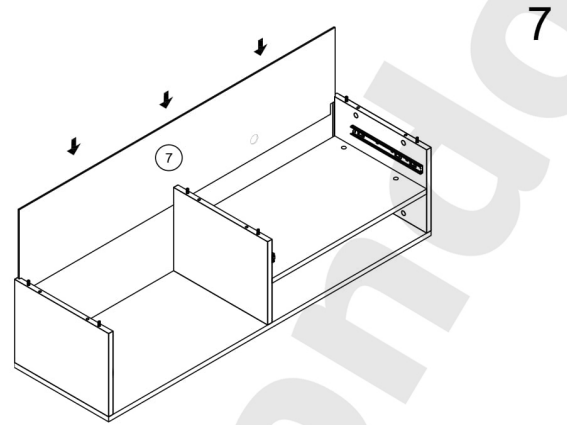
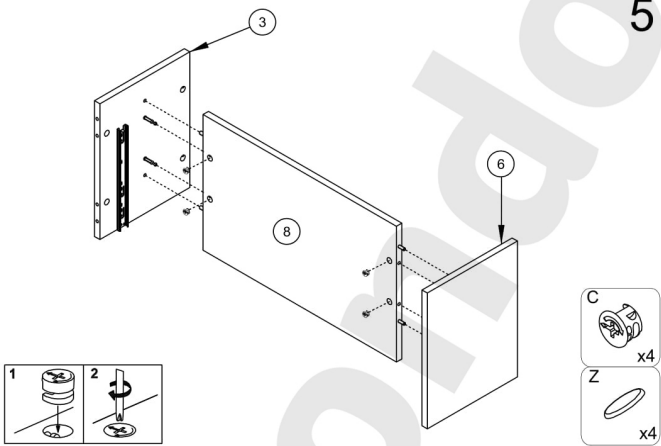

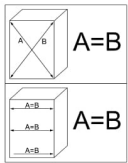

9

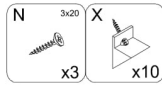
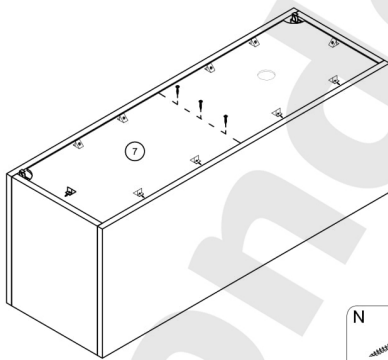

11

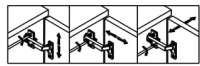
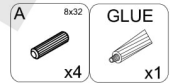
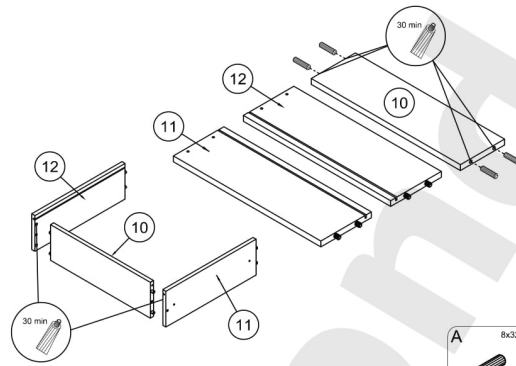

10

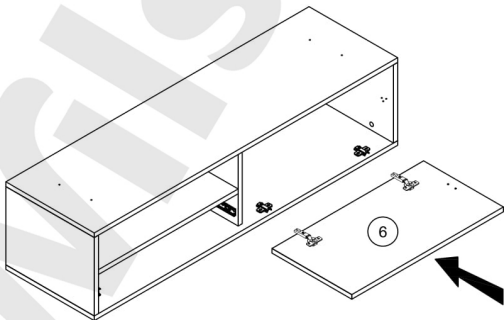

12

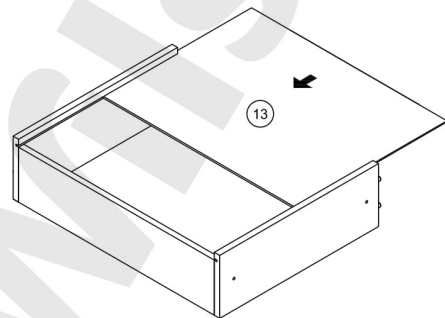

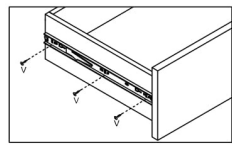

12

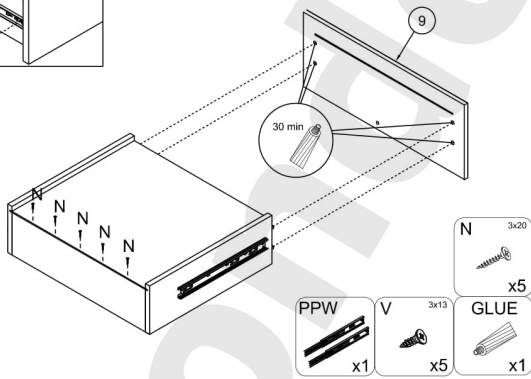

14

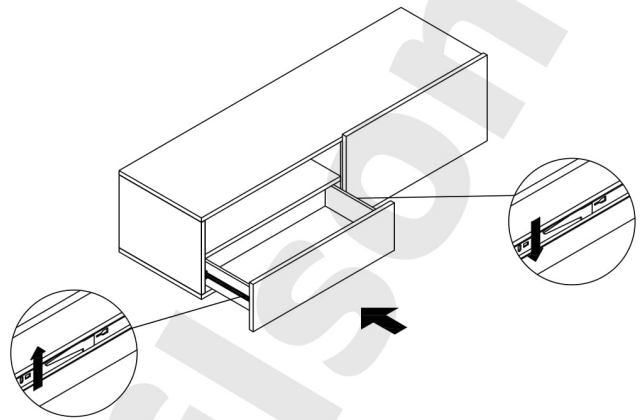

13

